

GS  
▽▽ (▽▽▽)

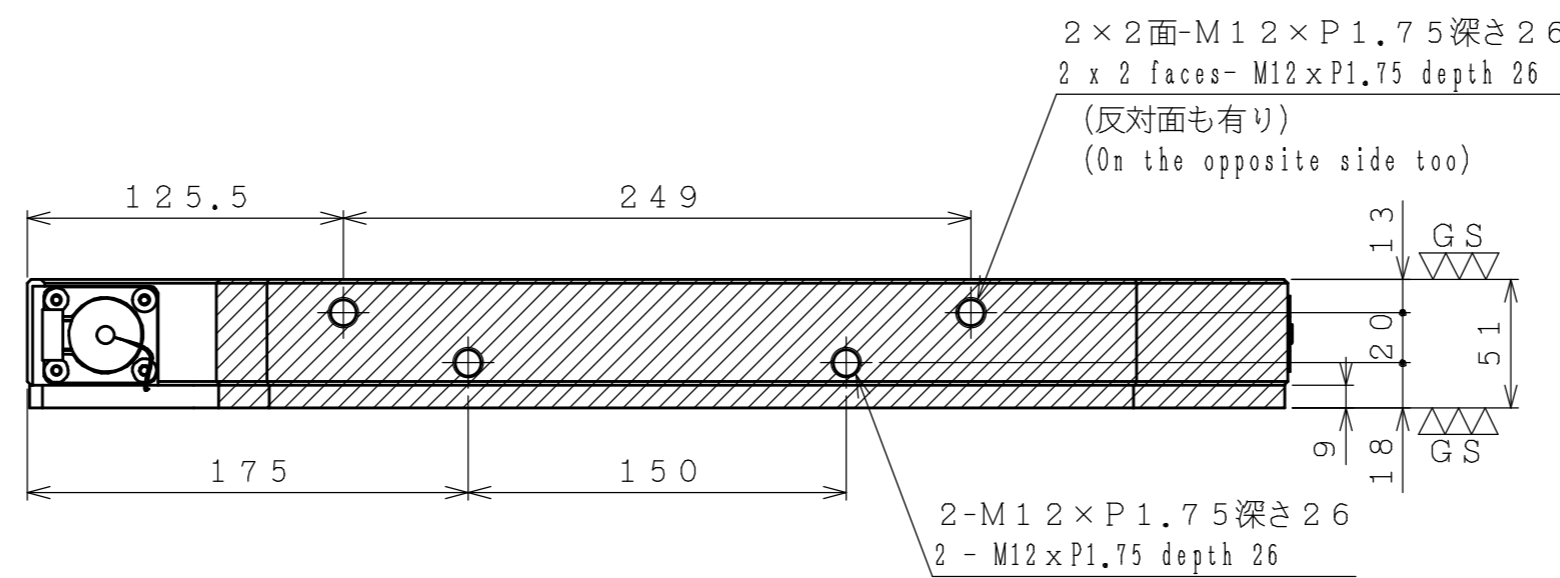
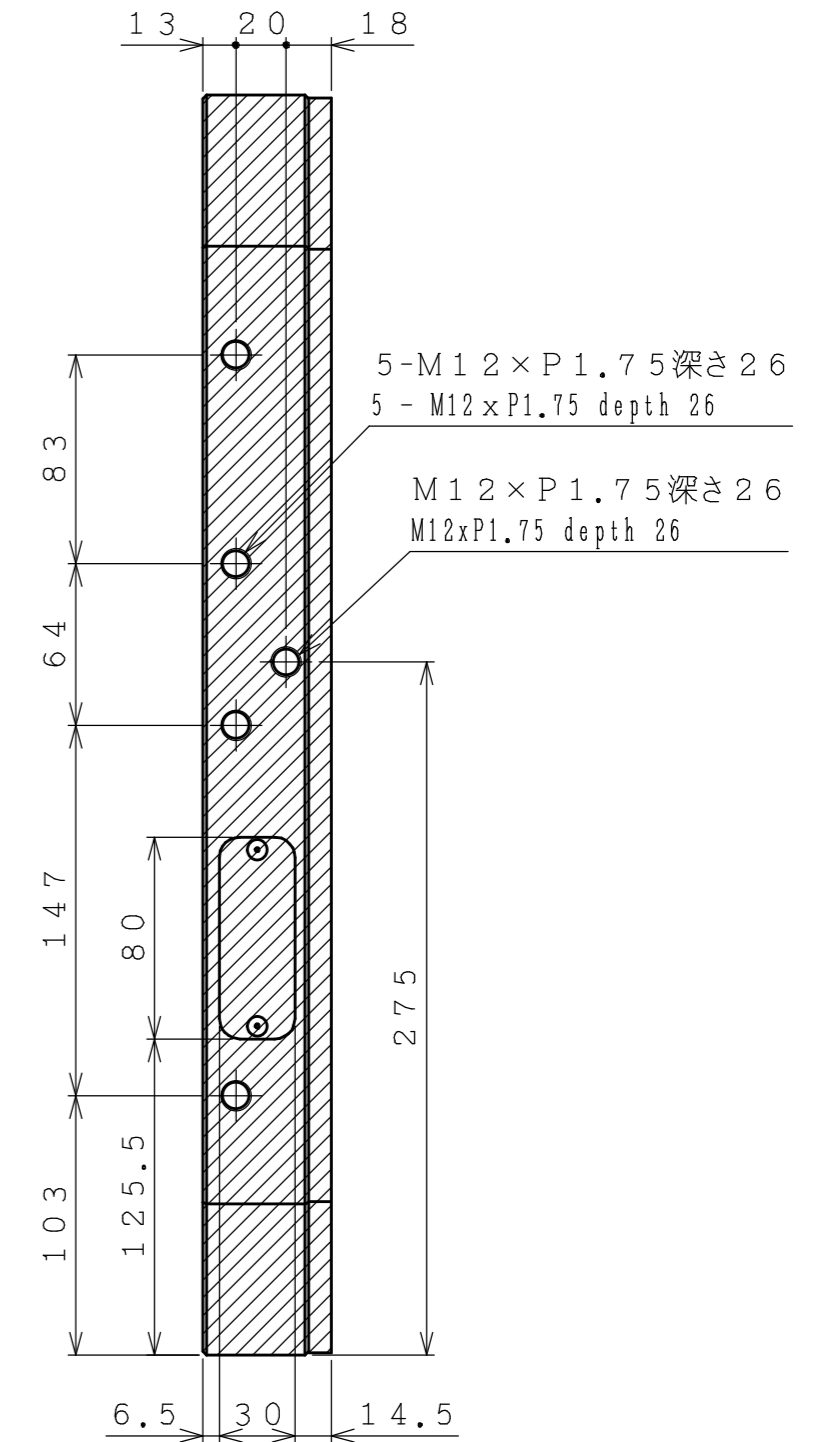
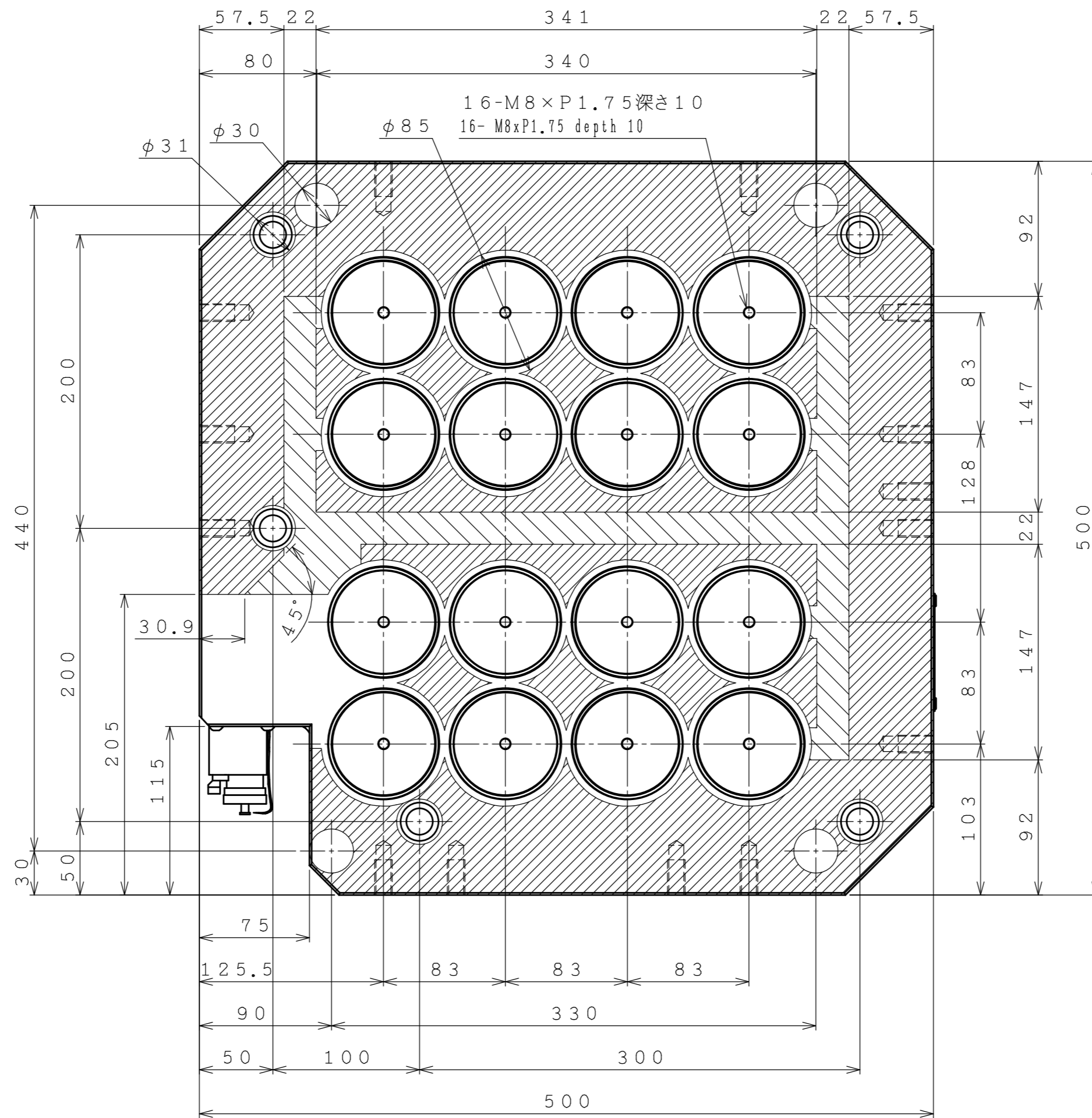
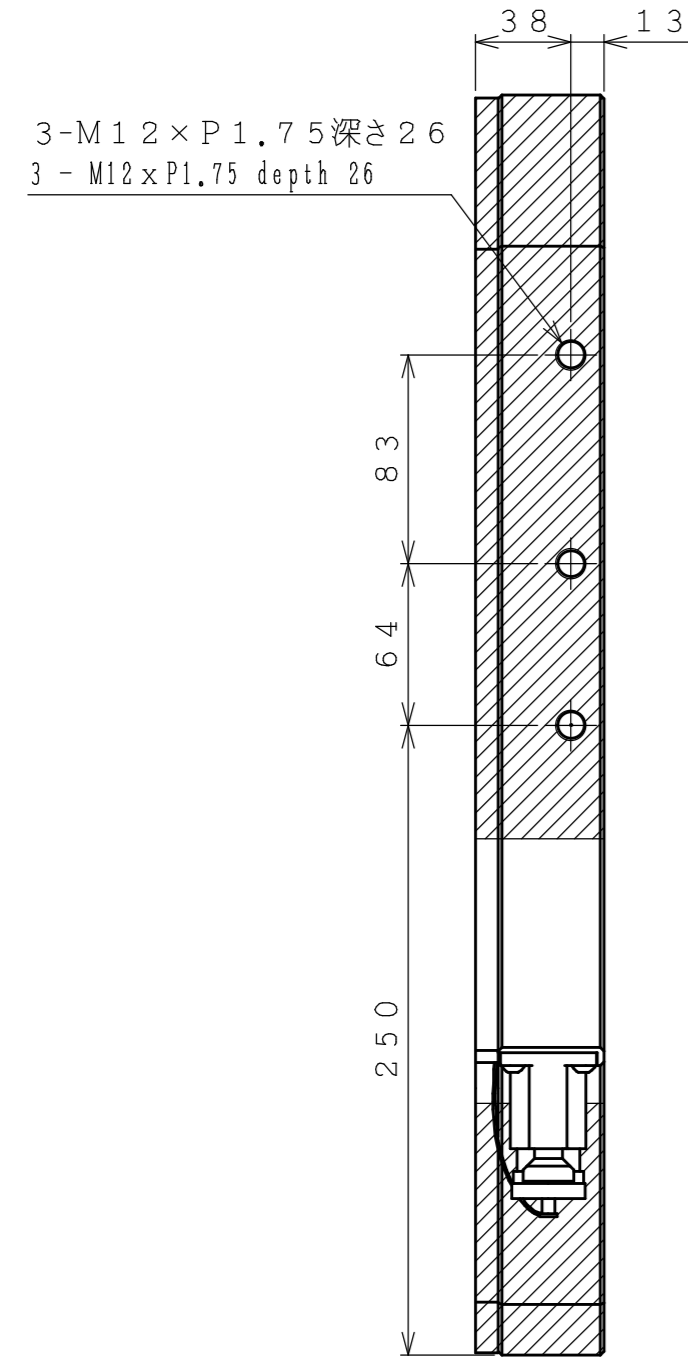
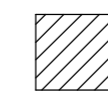
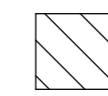
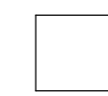

-  貫通加工可能  
Through hole can be machined.
-  上面から深さ 23mm まで加工可能  
Machining is possible from upper face up to 23mm.
-  追加工不可能  
Additional machining is not possible.

重量: 88 kg  
Weight

・ボトムプレートは取り外し不可です。  
Please don't remove a bottom plate from chuck body.  
・全面の加工代 (上面: 0.5mm, 下面: 1mm)  
Machining allowance for self-cutting (Top: 0.5mm, Bottom: 1mm)

コントローラー Controller	電圧 Voltage	定格容量 Rating capacity	MODEL No.	MTBP500HD70S1	
			DATE	2018.01.24	株式会社 ナベヤ NABEYA CO., LTD
NMC-100	200/230V	1.7/2.1kVA	SCALE	1/3	
NMC-200	200/230V	3.4/4.2kVA	ORDER No.	135692	