

2 x 2面-M12深さ26
 2 x 2 faces- M12 depth 26
 (反対面にもあり)
 (On the opposite side too)

- 貫通加工可能
Through hole can be machined.
- 上面から深さ23mmまで加工可能
Machining is possible from upper face up to 23mm.
- 追加工不可能
Additional machining is not possible.

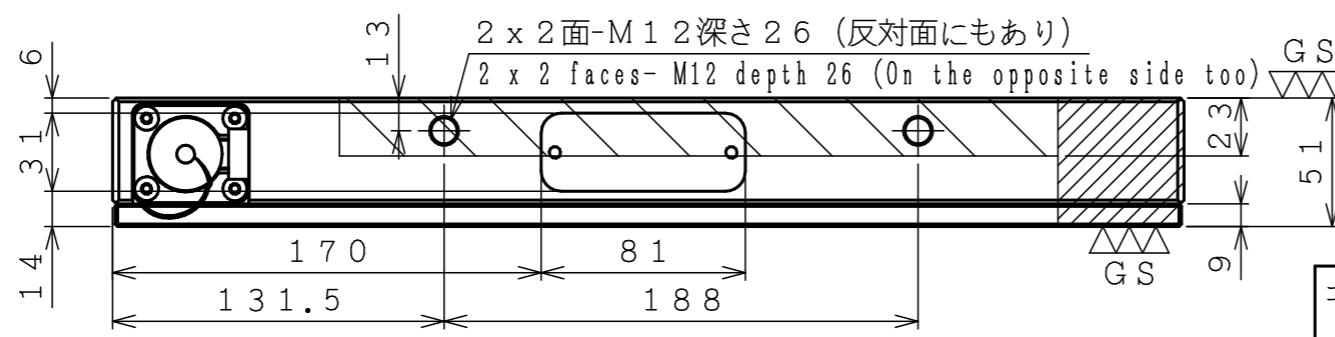

- ・ボトムプレートは取り外し不可です。
Please don't remove a bottom plate from chuck body.
- ・全面の加工代 (上面: 0.5mm, 下面: 1mm)
Machining allowance for self-cutting (Top: 0.5mm, Bottom: 1mm)

重量: 76kg
 Weight

コントローラー Controller	電圧 Voltage	定格容量 Rating Capacity	MODEL No.	MTB504HD70	
NMC-100	200/230V	1.9/2.4kVA	DATE	2018.01.24	株式会社 ナベヤ NABEYA CO., LTD
NMC-200	200/230V	3.8/4.8kVA	SCALE	1/3	
			ORDER No.	107706	